

The CP387 is a single-width, 6U, CompactPCI module with up to 256 digital input/output channels.

Four mezzanine card sites can be populated with other forms of digital I/O including isolated input, isolated output, relay output, AC switch output or differential I/O.

TYPICAL APPLICATIONS

Automotive test cells

Industrial monitoring and control

Automatic Test Equipment (ATE)

Monitoring and driving TTL-level signals

Driving relays, solenoids or lamps

CP387

Single-width, 6U CompactPCI module



KineticSystems' CP387 is a single-width, 6U, CompactPCI module with up to 256 digital input/output channels.

FEATURES

- 256 channel Digital Input/Output Channels
- 128 Base card channels
- 4 mezzanine card sites for added I/O capability including:
 - TTL I/O
 - Differential I/O
 - Isolated Input
 - Isolated Output
 - Form "A" Relay Output
 - Form "C" Relay Output
 - AC switch Output
- Change Of State Recognition
- Pattern Recognition
- Input and Output Strokes
- Programmable contact-bounce suppression on inputs

GENERAL DESCRIPTION

The CP387 is a single-width, 6U, CompactPCI module with up to 256 digital input/output channels. The CP387 base board supports 128 channels of TTL I/O. Four mezzanine card sites can be populated with other forms of digital I/O including isolated input, isolated output, relay output, AC switch output or differential I/O. The mezzanine card concept allows multiple digital I/O types to be configured within a single module to match the application requirements.

Pattern Recognition and Change Of State detection are included. Both operations can be used on the base card as well as span to the mezzanine channels. Input and output strobes are provided for connection to external sources.

The digital inputs and outputs are available on 3 double stacked 68 position high density connectors.

BASIC CIRCUIT OPERATION

The CP387 base-board provides 128 TTL level digital I/O channels. Expansion of up to 128 digital channels is provided by 4 mezzanine card sites. These sites can be populated with an assortment of I/O options to extend the capability of the CP387.

Data transfers to and from the CP387 are under programmed control and support 16 and 32 bit data words. Transfers to and from the base-board channels are executed directly. Transfers to the mezzanine card sites are translated by the base-board logic. The mezzanine card sites use an Industry Pack (IP) form factor and require the translation of PCI bus cycles to IP bus cycles.

Accessing digital output channels is accomplished by writing the selected data values to a register location. Reading digital input channels is also accomplished by simple register read operations.

The CP387 contains flash memory that can be used to restore basic digital input and output configuration parameters on power up. These parameters include the connection of either pull-up or pull-down resistors, the direction of digital I/O channels, and the initial power-up values of digital output channels.

Pattern recognition and change-of-state operations are supported by the CP387 base-board as well as by mezzanine plug on cards. The base-board performs these two operations by latching the digital input data from all sources and then performing a compare for the selected operation. If enabled, an interrupt can be generated at the conclusion of a pattern recognition or change-of-state operation.

Digital input and output strobes are provided on both the base-board and the mezzanine cards. A strobe signal connected to any of the first 16 channels on the base board can be routed under software control to digital input channels. Programmable contact debounce suppression is provided to prevent false detection of digital input glitches.

SOFTWARE

The CP387 comes with a Plug and Play driver for configuring and using the device and application examples to illustrate its basic functionality.

This and other tools, including their source code, are provided.

CP387 Block Diagram

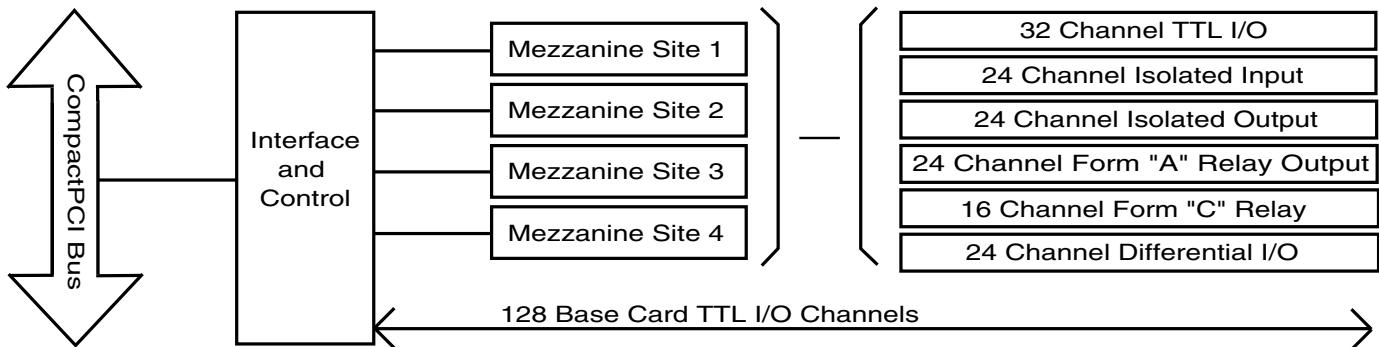

CP387 Specifications (Base-Board)

Item	Specifications
Number of Channels	128 Base-board Channels, and up to an additional 128 channels through expansion provided by the 4 mezzanine card sites.
I/O Type	Single-ended TTL
Direction Control	Yes, in Groups of 8 channels
Input Switching Threshold "0" Level "1" Level	0.2 V maximum 2.2V minimum
Output Voltage Threshold "0" Level "1" Level	0.4 V maximum (Iout = 2.5 mA) 2.7 V minimum (Iout = 2.5 mA)
Low Level Output Current	TBD
High Level Output Current	TBD
Input Current	TBD
Input Strobes Supported	Yes, Maximum of 16 (shared with output strobe count)
Input Strobe Polarity	Programmable
Input Strobe Pulse Width	200 nanoseconds minimum
Output Strobes Supported	Yes, Maximum of 16 (shared with input strobe count)
Output Strobe Polarity	Programmable
Output Strobe Delay	Programmable: 100 nanoseconds and 1 microsecond
Output Strobe Width	200 nanoseconds
Debouncing Rates	Programmable: Disabled, 1 microsecond, 1 millisecond, 10 milliseconds and 100 milliseconds
Input/Output Connector Type	3 Double-stacked 68 position High Density connectors
Power Requirements +5 V +3.3V +12 V -12 V	TBD TBD TBD TBD
Environmental and Mechanical Temperature range Operational Storage Relative humidity Cooling requirements Dimensions Front-panel potential	 0°C to +50°C -25°C to +75°C 0 to 85%, non-condensing to 40°C 10 CFM 233.35 mm x 160 mm (6U CompactPCI module) Chassis ground

Technical specifications contained within this publication are subject to change without notice.

IP380 Specifications 32 Channel TTL Bi-directional I/O Mezzanine Module

Item	Specifications
Number of Channels	32
I/O Type	Single-ended TTL
Direction Control	Yes, in Groups of 8 channels
Input Switching Threshold "0" Level "1" Level	0.2 V maximum 2.2V minimum
Output Voltage Threshold "0" Level "1" Level	0.4 V maximum (Iout = 2.5 mA) 2.7 V minimum (Iout = 2.5 mA)
Low Level Output Current	TBD
High Level Output Current	TBD
Input Current	TBD
Input Strobe Supported	Yes
Input Strobe Polarity	Programmable
Input Strobe Pulse Width	200 nanoseconds minimum
Output Strobe Supported	Yes
Output Strobe Polarity	Programmable
Output Strobe Delay	Programmable: 100 nanoseconds and 1 microsecond
Output Strobe Width	200 nanoseconds
Debouncing Rates	Programmable: Disabled, 1 microsecond, 1 millisecond, 10 milliseconds and 100 milliseconds
Input/Output Connector Type	50 position Industry Pack Connector interface through the CP387 base board and routed to a 68 position high density connector.
Power Requirements +5 V +12V -12 V	TBD TBD TBD

Technical specifications contained within this publication are subject to change without notice.

IP381 Specifications 24 Channel Isolated Input Mezzanine Module

Item	Specifications
Number of Channels	24
I/O Type	Isolated Input
Direction Control	Input Only
Voltage Levels Supported	5 V dc, 12V dc, 16 V dc, 24 V dc, 28 V dc, 48 V dc, or 120 V ac
Input Isolation	500 V
Input Current	Greater than 5 mA, less than 15 mA
Switching Threshold	Nominally one-half of the rated input
Input Strobe Supported	Yes
Input Strobe Polarity	Programmable
Input Strobe Pulse Width	TBD nanoseconds minimum
Debouncing Rates	Programmable: Disabled, 1 microsecond, 1 millisecond, 10 milliseconds and 100 milliseconds
Input/Output Connector Type	50 position Industry Pack Connector interface through the CP387 base board and routed to a 68 position high density connector.
Power Requirements	
+5 V	TBD
+12 V	TBD
-12 V	TBD

Technical specifications contained within this publication are subject to change without notice.

IP382 Specifications 24 Channel Isolated Output Mezzanine Module

Item	Specifications
Number of Channels	24
I/O Type	Optically Isolated Input
Direction Control	Output Only
Maximum Open Circuit Voltage	30 V
Maximum ON Current	10 mA
ON Voltage Drop	1V maximum
Off Current	1 μ A maximum
Output Strobe Supported	Yes
Output Strobe Polarity	Programmable
Output Strobe Pulse Width	TBD nanoseconds minimum
Input/Output Connector Type	50 position Industry Pack Connector interface through the CP387 base board and routed to a 68 position high density connector.
Power Requirements	
+5 V	TBD
+12 V	TBD
-12 V	TBD

IP383 Specifications 24 Channel Form "A" Relay Output

Item	Specifications
Number of Channels	24
I/O Type	Relay
Direction Control	Output Only
Output Configuration	1 Form "A" Relay
Maximum Open Circuit Voltage	100 V dc
Maximum Current	300 mA
Maximum Switched Load	TBD VA
Life Expectancy	TBD X 10 ⁶ operations (with proper contact protection)
Contact Resistance	TBD m Ω , maximum
Operate Time	TBD mS, maximum
Release Time	TBD mS, maximum
Insulation Resistance	TBD M Ω , minimum
Contact Bounce	TBD mS
Output Strobe Supported	No
Input/Output Connector Type	50 position Industry Pack Connector interface through the CP387 base board and routed to a 68 position high density connector.
Power Requirements	
+5 V	TBD
+12 V	TBD
-12 V	TBD

Technical specifications contained within this publication are subject to change without notice.

IP384 Specifications 16 Channel Form "C" Relay Output

Item	Specifications
Number of Channels	16
I/O Type	Relay
Direction Control	Output Only
Output Configuration	1 Form "C" Relay
Maximum Open Circuit Voltage	100 V
Maximum Current	300 mA
Maximum Switched Load	TBD VA
Life Expectancy	TBD X 10 ⁶ operations (with proper contact protection)
Contact Resistance	TBD mΩ, maximum
Operate Time	TBD mS, maximum
Release Time	TBD mS, maximum
Insulation Resistance	TBD MΩ, minimum
Contact Bounce	TBD mS
Output Strobe Supported	No
Input/Output Connector Type	50 position Industry Pack Connector interface through the CP387 base board and routed to a 68 position high density connector.
Power Requirements	
+5 V	TBD
+12 V	TBD
-12 V	TBD

IP386 Specifications 16 Channel AC Switch Output Mezzanine Module

Item	Specifications
Number of Channels	16
I/O Type	AC Switched Output
Direction Control	Output Only
Zero Voltage Turn-on	10 V peak
Maximum Open Circuit Voltage	130 V RMS (200 V peak)
Maximum ON Current	300 mA, 47-70 Hz
Minimum ON Current	0.01 A
ON Voltage Drop	1.6V RMS, maximum (at rated current)
Turn-on Time (60 Hz)	8.3 mS, maximum
Turn-off Time (60 Hz)	8.4 mS, maximum
Input/Output Connector Type	50 position Industry Pack Connector interface through the CP387 base board and routed to a 68 position high density connector.
Power Requirements	
+5 V	TBD
+12 V	TBD
-12 V	TBD

Technical specifications contained within this publication are subject to change without notice.

IP385 Specifications 24 Channel Differential Bi-directional I/O Mezzanine Module

Item	Specifications
Number of Channels	24
I/O Type	Differential I/O conforming to RS-422 signal levels
Direction Control	Yes, in Groups of 8 Channels
Driver Termination	50 Ω in series with each leg
Receiver Termination	100 Ω across the differential path
Maximum Input Voltage	± 7 V
Input Resistance	6 k Ω
Differential Input Sensitivity	+2 V maximum, -2V minimum
Driver Output Voltage "0" Level "1" Level	+0.5 V maximum, +2.5 V minimum
Driver short Circuit Current	-150 mA maximum, -30 mA minimum
Input Strobe Supported	Yes
Input Strobe Polarity	Programmable
Input Strobe Pulse Width	200 nanoseconds minimum
Output Strobe Supported	Yes
Output Strobe Polarity	Programmable
Output Strobe Delay	Programmable: 100 nanoseconds and 1 microsecond
Output Strobe Width	200 nanoseconds
Debouncing Rates	Programmable: Disabled, 1 microsecond, 1 millisecond, 10 milliseconds and 100 milliseconds
Input/Output Connector Type	50 position Industry Pack Connector interface through the CP387 base board and routed to a 68 position high density connector.
Power Requirements +5 V +12 V -12 V	TBD TBD TBD

Technical specifications contained within this publication are subject to change without notice.

ORDERING INFORMATION

CP387-ZA11	256 Channel Digital I/O Base Board
IP380-AA11	32 Channel TTL Bi-directional I/O Mezzanine Module
IP381-AA11	24 Channel Isolated Input Mezzanine Module, 5V dc
IP381-AA21	24 Channel Isolated Input Mezzanine Module, 12V dc
IP381-AA31	24 Channel Isolated Input Mezzanine Module, 16V dc
IP381-AA41	24 Channel Isolated Input Mezzanine Module, 24V dc
IP381-AA51	24 Channel Isolated Input Mezzanine Module, 28V dc
IP381-AA61	24 Channel Isolated Input Mezzanine Module, 48V dc
IP381-AA71	24 Channel Isolated Input Mezzanine Module, 120V ac
IP382-AA11	24 Channel Isolated Output Mezzanine Module
IP383-AA11	24 Channel Form "A" Relay Output Mezzanine Module
IP384-AA11	16 Channel Form "C" Relay Output Mezzanine Module
IP385-AA11	24 Channel Differential Bi-directional I/O Mezzanine Module
IP386-AA11	16 Channel AC Switch Output Mezzanine Module

Specifications contained within this data sheet are subject to change without notice.

Updated July 26th, 2005

Copyright © 2005 KineticSystems Company, LLC. All rights reserved.

KineticSystems Company, LLC

900 N. State St.
Lockport, IL 60441-2200

Toll-Free (US and Canada):

phone 1-800-DATA NOW
1-800-328-2669

Direct:

phone +1-815-838-0005
fax +1-815-838-4424

Email:

mkt-info@kscorp.com

To find your local sales representative or distributor or to learn more about KineticSystems' products visit:

www.kscorp.com