

The V275 is a single-width, C-size, register-based, VXIbus module for generating eight output voltages. The standard output is 0 to +10 V with a maximum load of 5 mA.

Options of the module are available with output ranges of 0 to +5 V, ± 2.5 V, ± 5 V, and ± 10 V.

APPLICATIONS

Industrial control
Automatic Test Equipment (ATE)
General-purpose control applications

V275 8-channel, 12-bit DAC



An economical choice for low-channel-count applications

FEATURES

- 8 independent analog outputs
- 5 output voltage options
- 12-bit resolution (one part in 4096)
- 5 mA drive capability
- Low drift
- 4 μ s settling time
- Outputs reset to 0 V at power-on

The V275 is a single-width, C-size, register-based, VXIbus module for generating eight output voltages. The standard output is 0 to +10 V with a maximum load of 5 mA. Options of the module are available with output ranges of 0 to +5 V, ± 2.5 V, ± 5 V, and ± 10 V. A 12-bit register is provided for each channel. The data is written in two's complement format, and is right-justified (i.e., the LSB is written to D00). Settling time of the output to within 1/2 LSB is less than 4 μ s. The output impedance is less than 100 m Ω . The outputs of the V275 will withstand an indefinite short circuit to ground.

The V275 is calibrated at the factory for zero offset and accurate gain. All outputs are referenced to a common ground (module ground). In critical applications, these signals should be received by differential input circuits.

The V275 supports both static and dynamic configuration. Access to the dual-ported memory is via memory locations pointed to by the Offset Register within the VXIbus Configuration Register set, using A24/16, D16 data transfers. All eight channels are accessed using the same VXIbus address.

V275 Block Diagram

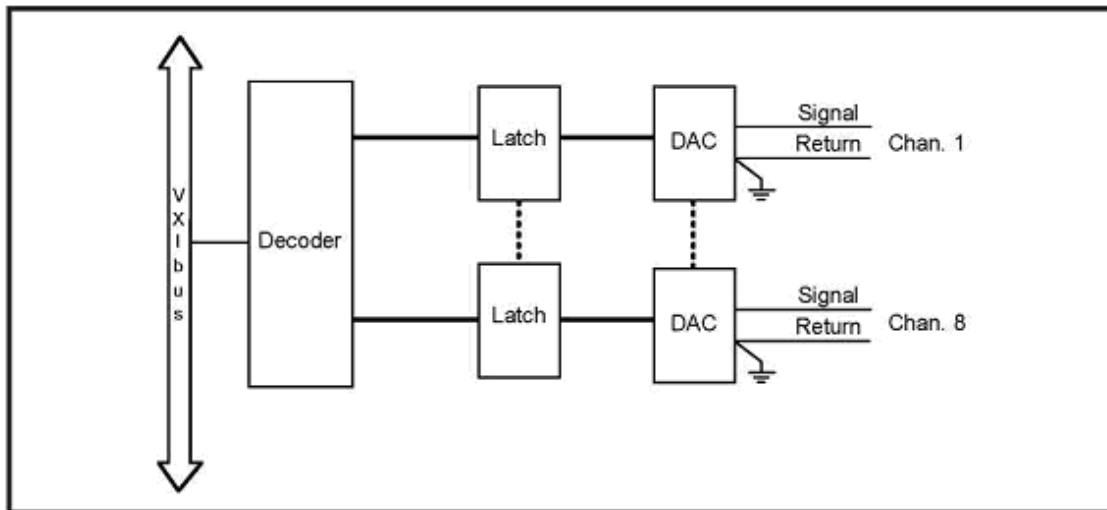



ITEM	SPECIFICATION
Number of Channels	8
Full-scale Output	0 to +10 V, 0 to +5 V, ± 2.5 V, ± 5 V, and ± 10 V (by order option)
Resolution	12 bits (one part in 4096)
Linearity Error	$\pm 1/2$ LSB
Monotonicity	Monotonic to 12 bits
Output Impedance	Less than 0.1 Ω
Output Current	± 5 mA
Output Protection	Can withstand short circuit to ground
Settling Time	4 μ s, maximum to within Vi LSB for a 20 V change
Output Connector Types	2-contact LEMO connectors
Mating Connectors	KineticSystems Model 5911-Z1A
Power Requirements +5 V +24 V -24 V	1.6 A, typical 100 mA, typical 200 mA, typical
Environmental and Mechanical Temperature range Operational Storage Relative humidity Cooling requirements Dimensions Front-panel potential	0°C to +50°C -25°C to +75°C 0 to 85%, non-condensing to 40°C 10 CFM 340 mm x 233.35 mm x 30.48 mm (C-sized VXIbus) Chassis ground

RELATED PRODUCTS

Model 5857-Cxyz Cable—2-contact LEMO to Unterminated
 Model 5857-Dxyz Cable—2-contact LEMO to 2-contact LEMO
 Model 5857-Gxyz Cable—1-contact LEMO to BNC shielded
 Model 5 911 -Z1A Connector—2-contact LEMO

ORDERING INFORMATION

MODEL	DESCRIPTION
V275-MA11	8-channel, 12-bit D/A converter; 0 to +5 V output
V275-MB11	8-channel, 12-bit D/A converter; 0 to +10 V output
V275-MC11	8-channel, 12-bit D/A converter; ± 2.5 V output
V275-MD11	8-channel, 12-bit D/A converter; ± 5 V output
V275-ME11	8-channel, 12-bit D/A converter; ± 10 V output

Updated October 24, 2005

Copyright © 2005 KineticSystems Company, LLC. All rights reserved.

KineticSystems Company, LLC

900 N. State St.
 Lockport, IL 60441-2200

Toll-Free (US and Canada):

phone 1-800-DATA NOW
 1-800-328-2669

Direct:

phone +1-815-838-0005
 fax +1-815-838-4424

Email:

mkt-info@kscorp.com

To find your local sales representative or distributor or to learn more about KineticSystems' products visit:

www.kscorp.com